



REVOLUTION
RACE CARS

Arrive & Drive Race Drive Proposal

Dec 2023

Events :

2024 Sports Prototype Cup Season

2024 Calendar

- 12 - 14 Apr : **Zandvoort** : 2 x 25min races 1 x 40min races
- 31 May - 2 June : **Spa Francorchamps** : 2 x 60min races
- 22 June : **Donington GP** : 2 x 30min races
- 21 - 25 Aug : **Watkins Glen** : 1 x 30 min race 2 x 60 min race
- 13 - 15 Sep : **Zandvoort** : 2 x 25min races 1 x 40min races
- 25-27 Oct : **TT Circuit Assen** : 2 x 25min races 1 x 40min races
- 16 - 17 Nov : **Le Mans Bugatti** : 2 x 20min races 1 x 40min races

- NB Watkins Glen is a none points scoring invitational round



2024 Sports Prototype Cup

The SPC in 2024 will have unique selling points:

- **Best European Circuits**

We have committed to selecting the finest European circuits to ensure a memorable and challenging racing experience.

- **Sprint & Endurance Events**

The season features a well-balanced blend of sprint and endurance races, catering to both solo drivers and teams of two. This design not only provides ample track time but also offers a varied set of challenges for all participants.

- **USA v Europe:**

2023 saw the launch of Sports Prototype Cup North America with events at top USA and Canadian circuits. To strengthen this partnership, European drivers will be invited to join one of their flagship events on the famous Watkins Glen circuit in New York state.



Crème de la crème of European circuits

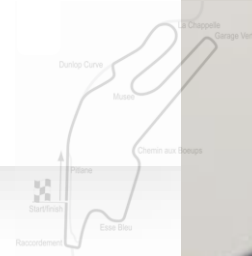
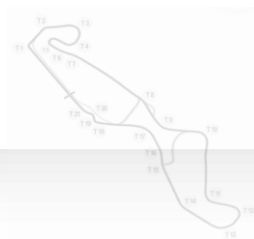
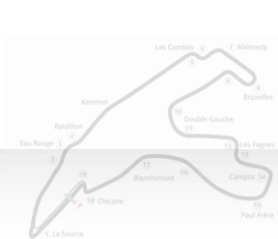

Circuit Zandvoort

- Track length: **4.259km**
- Left hand corners: **5**
- Right hand corners: **10**
- Corners: **15**
- Circuit opened: **1939**

Spa Francorchamps

- Track length: **7.004km**
- Left hand corners: **9**
- Right hand corners: **10**
- Corners: **19**
- Circuit opened: **1925**

Donington GP

- Track length: **4.02KM**
- Left hand corners: **5**
- Right hand corners: **7**
- Corners: **12**
- Circuit opened: **1931**

TT Circuit Assen

- Track length: **4.55KM**
- Left hand corners: **7**
- Right hand corners: **14**
- Corners: **21**
- Circuit opened: **1955**

Le Mans Bugatti

- Track length: **4.27km**
- Left hand corners: **5**
- Right hand corners: **9**
- Corners: **14**
- Circuit opened: **1965**



Revolution 427

- A-One 427
- BHP : 427
- Top Speed : 255 km/h
- 100 – 200 km/h : 6.2s
- Weight: 820kg





#SUPERCHARGED

The car : Revolution 500SC

- A-One 500SC
- BHP : 500
- Top Speed : 285 km/h
- 100 – 200 km/h : 5.7s
- Weight: 834kg



The first truly affordable sports racer with a carbon safety cell and cutting-edge technology

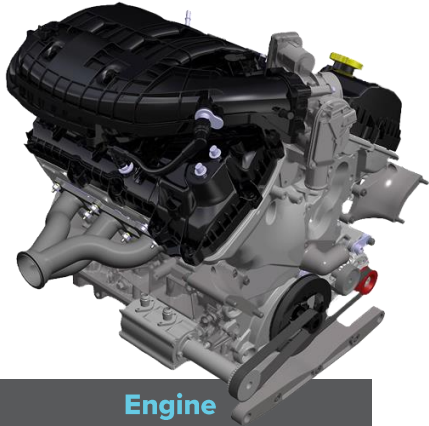

Engine

Developed from a Ford-based V6 unit, the Revolution A-One engine has proven reliability to match its high-end performance.

Tuned and prepared for high-energy track work, the power unit is one of the many highlights of this car, with a large torque spread and an epic soundtrack. It also has the reliability, easy servicing and long refresh intervals.

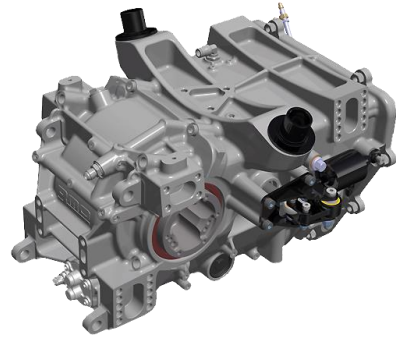

Gearbox

Mated to the engine is a bespoke 6-speed paddle shift gearbox built by 3MO.

With lightning-fast up-shifts and perfectly blipped down-shifts, it's casing is loadbearing, with the suspension mounted directly onto it.



Chassis

The FIA-approved carbon safety cell is both reassuringly strong and spacious enough to fit the largest of drivers and passengers.

It is created by an infusion process developed by DD Composites that keeps the manufacturing costs low but the quality high.

It's also fitted with the world's first double halo system ensuring the highest levels of occupant protection.



Suspension

Double-wishbones meet inboard dampers and adjustable anti-roll bars front and rear.

The dampers are three-way adjustable and have been developed specifically for the A-One.

It will out-handle anything in its class and has been described by very experienced pro-drivers as the best car they've ever driven.

To reduce running costs and spares requirements, components such as the uprights and rockers are identical at each corner.



Control Centre

The Revolution F1-style steering wheel is a piece of art.

Manufactured in carbon, the steering wheel features multiple push and rotary buttons for easy control of engine performance, traction control and brake bias, with ideally-placed buttons for comms, the pit lane speed limiter, data markers and much more.

The wheel centre displays all the required driving information in multiple formats to match every driver's preferences. Full downloadable video data analysis is also available.



Double-halo : another Revolution first

Exceeding FIA standards, the double-halo head protection is inspired by that mandated in Formula One



“The closest car I’ve driven to a Le Mans Prototype car!”

Sir Chris Hoy

- 2015 LMP3 Champion
- Le Mans 24-hour driver
- Six-time Olympic champion
- Eleven-time World champion

April Zandvoort race package includes

- 40 mins free practice (minimum)
- 1 x 20 mins quali
- 2 x 25 min races and 1 x 40 min race
- 1 x No. 1 mechanic (dedicated)
- 1 x No. 2 mechanic (shared)
- 1 x Data engineer (shared)
- 1 x Driver coach (shared)
- 2 sets new slicks included
- Serviceable wets supplied if necessary
- Damage not included. Charged as necessary
- **500SC : £17,495 Total**
- **427 : £15,905 Total**



June Spa Francorchamps race package includes

- 80 mins free practice (minimum)
- 1 x 20 mins quali
- 2 x 60 min races
- 1 x No. 1 mechanic (dedicated)
- 1 x No. 2 mechanic (shared)
- 1 x Data engineer (shared)
- 1 x Driver coach (shared)
- 2 sets new slicks included
- Serviceable wets supplied if necessary
- Damage not included. Charged as necessary
- **500SC : £20,390 Total**
- **427 : £18,060 Total**

June Donington GP race package includes

- Optional test day
- 1 x 20 mins quali
- 2 x 30 min races
- 1 x No. 1 mechanic (dedicated)
- 1 x No. 2 mechanic (shared)
- 1 x Data engineer (shared)
- 1 x Driver coach (shared)
- 1 set new slicks included
- Serviceable wets supplied if necessary
- Damage not included. Charged as necessary
- **500SC : £8,960 Total**
- **427 : £8,110 Total**
- **+VAT if applicable**

Sep Zandvoort race package includes

- 30 mins free practice (minimum)
- Optional further test time
- 1 x 30 mins quali
- 2 x 25 min races and 1 x 40 min race
- 1 x No. 1 mechanic (dedicated)
- 1 x No. 2 mechanic (shared)
- 1 x Data engineer (shared)
- 1 x Driver coach (shared)
- 2 sets new slicks included
- Serviceable wets supplied if necessary
- Damage not included. Charged as necessary
- **500SC : £17,495 Total**
- **427 : £15,905 Total**



Oct TT Circuit Assen race package includes

- 30 mins free practice (minimum)
- Optional further test time
- 1 x 20 mins quali
- 2 x 25 min races and 1 x 40 min race
- 1 x No. 1 mechanic (dedicated)
- 1 x No. 2 mechanic (shared)
- 1 x Data engineer (shared)
- 1 x Driver coach (shared)
- 2 sets new slicks included
- Serviceable wets supplied if necessary
- Damage not included. Charged as necessary
- **500SC : £17,090 Total**
- **427 : £15,605 Total**

Nov Le Mans Bugatti race package includes

- 45 mins free practice (minimum)
- 1 x 20 mins quali
- 2 x 20 min races and 1 x 40 min race
- 1 x No. 1 mechanic (dedicated)
- 1 x No. 2 mechanic (shared)
- 1 x Data engineer (shared)
- 1 x Driver coach (shared)
- 2 sets new slicks included
- Serviceable wets supplied if necessary
- Damage not included. Charged as necessary
- **500SC : £17,480 Total**
- **427 : £15,940 Total**





Optional Insurance

Example pricing

- £5,885 per meeting
- £7,500 excess
- £100,000 insured

Or

- £2,745 per meeting
- £7,500 excess
- £35,000 insured



Contact :

nigel@revolutionracecars.com

Mobile: + 44 (0) 7818 047 866