



REVOLUTION
RACE CARS

Arrive & Drive Race Drive Proposal

Feb 2024

Events :

**2024 Revolution Cup North America
East Coast**

Arrive and Drive

Arrive and drive services
provided by Certified Dealer
Classic Car Club



2024 SCHEDULE



PRESENTED BY  **Hankook**

PSSA East

Eagles Canyon Raceway

Decatur, Texas
March 7-10

Road Atlanta

Braselton, Ga.
March 21-24

Road America

Plymouth, Wis.
June 28-30

Lime Rock Park

Lakeville, Conn.
July 19-20

Watkins Glen International

Watkins Glen, N.Y.
August 21-25

Virginia International Raceway

Alton, Va.
October 3-6

Circuit of The Americas

Austin, Texas
October 31 - November 3

PSSA West

Thunderhill Raceway Park

Willows, Calif.
March 1-3

Sonoma Raceway

Sonoma, Calif.
April 18-21

WeatherTech Raceway Laguna Seca

Salinas, Calif.
May 2-5

Road America

Plymouth, Wis.
June 28-30

Portland International Raceway

Portland, Ore.
July 26-28

Spring Mountain Motorsports Ranch

Pahrump, Nev.
October 18-20

Circuit of The Americas

Austin, Texas
October 31 - November 3



2024 Revolution Cup

Overview

The Revolution Cup is a championship within the Prototype Sprint Series Association (PSSA). The PSSA is dedicated to showcasing prototype race cars in an exhilarating sprint race format. These races take place at some of the most iconic road courses in America.

The 2024 season promises even more action with the introduction of East, West, and Constructor's Championships, as well as the inclusion of new venues that will further elevate the competition.

Big prizes

There are big prizes on offer too. Each of the PSSA East and PSSA West Champions will be awarded a \$10,000 prize and the overall National Champion will be awarded a limited-edition Bell Racing gold helmet. In addition, the victor of the Revolution Cup has the enticing option to exchange their championship-winning car for a brand-new Revolution 500 EVO!





#SUPERCHARGED

The car : Revolution 500SC

- A-One 500SC
- BHP : 500
- Top Speed : 285 km/h
- 100 – 200 km/h : 5.7s
- Weight: 834kg



The first truly affordable sports racer with a carbon safety cell and cutting-edge technology

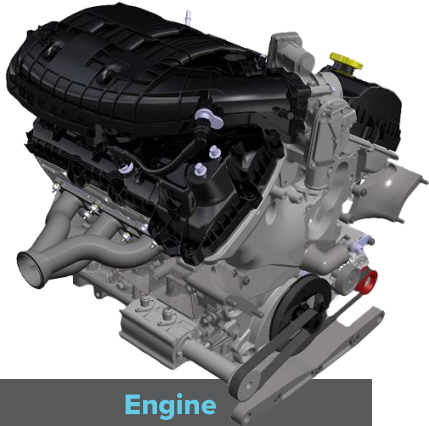

Engine

Developed from a Ford-based V6 unit, the Revolution A-One engine has proven reliability to match its high-end performance.

Tuned and prepared for high-energy track work, the power unit is one of the many highlights of this car, with a large torque spread and an epic soundtrack. It also has the reliability, easy servicing and long refresh intervals.

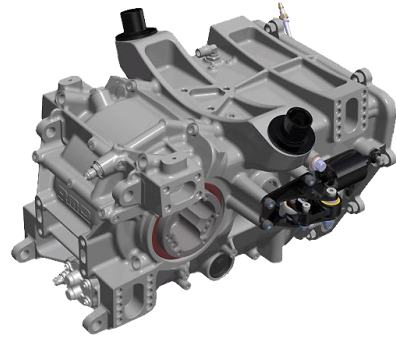

Gearbox

Mated to the engine is a bespoke 6-speed paddle shift gearbox built by 3MO.

With lightning-fast up-shifts and perfectly blipped down-shifts, it's casing is loadbearing, with the suspension mounted directly onto it.



Chassis

The FIA-approved carbon safety cell is both reassuringly strong and spacious enough to fit the largest of drivers and passengers.

It is created by an infusion process developed by DD Composites that keeps the manufacturing costs low but the quality high.

It's also fitted with the world's first double halo system ensuring the highest levels of occupant protection.



Suspension

Double-wishbones meet inboard dampers and adjustable anti-roll bars front and rear.

The dampers are three-way adjustable and have been developed specifically for the A-One.

It will out-handle anything in its class and has been described by very experienced pro-drivers as the best car they've ever driven.

To reduce running costs and spares requirements, components such as the uprights and rockers are identical at each corner.



Control Centre

The Revolution F1-style steering wheel is a piece of art.

Manufactured in carbon, the steering wheel features multiple push and rotary buttons for easy control of engine performance, traction control and brake bias, with ideally-placed buttons for comms, the pit lane speed limiter, data markers and much more.

The wheel centre displays all the required driving information in multiple formats to match every driver's preferences. Full downloadable video data analysis is also available.



Double-halo : another Revolution first

Exceeding FIA standards, the double-halo head protection is inspired by that mandated in Formula One



“The closest car I’ve driven to a Le Mans Prototype car!”

Sir Chris Hoy

- 2015 LMP3 Champion
- Le Mans 24-hour driver
- Six-time Olympic champion
- Eleven-time World champion



March Road Atlanta

- Test day
- 2 x quali
- 2 x PSSA sprint races
- 1 x No. 1 mechanic (dedicated)
- 1 x No. 2 mechanic (shared)
- 1 x Data engineer (shared)
- 1 x Driver coach (shared)
- 2 sets new slicks included
- Serviceable wets supplied if necessary
- Damage not included. Charged as necessary
- **500SC : \$25,000 Total**

June Road America

- Test day
- 2 x quali
- 2 x PSSA sprint races
- 1 x No. 1 mechanic (dedicated)
- 1 x No. 2 mechanic (shared)
- 1 x Data engineer (shared)
- 1 x Driver coach (shared)
- 2 sets new slicks included
- Serviceable wets supplied if necessary
- Damage not included. Charged as necessary
- **500SC : \$25,250 Total**

July Lime Rock

- Test day
- 2 x quali
- 2 x PSSA sprint races
- 1 x No. 1 mechanic (dedicated)
- 1 x No. 2 mechanic (shared)
- 1 x Data engineer (shared)
- 1 x Driver coach (shared)
- 2 sets new slicks included
- Serviceable wets supplied if necessary
- Damage not included. Charged as necessary
- **500SC : \$22,750 Total**



August Watkins Glen

- Test day
- 2 x quali
- 2 x PSSA sprint races
- 1 x No. 1 mechanic (dedicated)
- 1 x No. 2 mechanic (shared)
- 1 x Data engineer (shared)
- 1 x Driver coach (shared)
- 2 sets new slicks included
- Serviceable wets supplied if necessary
- Damage not included. Charged as necessary
- **500SC : \$23,250 Total**



October VIR

- Test day
- 2 x quali
- 2 x PSSA sprint races
- 1 x No. 1 mechanic (dedicated)
- 1 x No. 2 mechanic (shared)
- 1 x Data engineer (shared)
- 1 x Driver coach (shared)
- 2 sets new slicks included
- Serviceable wets supplied if necessary
- Damage not included. Charged as necessary
- **500SC : \$24,000 Total**





October COTA

- Test day
- 2 x quali
- 2 x PSSA sprint races
- 1 x No. 1 mechanic (dedicated)
- 1 x No. 2 mechanic (shared)
- 1 x Data engineer (shared)
- 1 x Driver coach (shared)
- 2 sets new slicks included
- Serviceable wets supplied if necessary
- Damage not included. Charged as necessary
- **500SC : \$29,000 Total**



Season offer

- 6 East coast events, \$149,250.
- Discount to pay in advance \$135,000.
- Pay in advance Includes two complimentary test days at NJMP.
- Includes standard PSSA a races, additional sessions, enduros or invitational events are extra.
- Normal consumables included, excessive wear and damage repairs are extra.



Contact :

nigel@revolutionracecars.com

or

zacm@classiccarclub.com

Nigel mobile: + 44 (0) 7818 047 866

Zac mobile : +1 646 331 8224